

NATIONAL EXAMS MAY 2012

98-CIV-B1 ADVANCED STRUCTURAL ANALYSIS

3 HOURS DURATION

NOTES:

1. If doubt exists as to the interpretation of any question, the candidate is urged to submit with the answer paper a clear statement of any assumption made.
2. Each candidate may use an approved model of Sharp or Casio calculator; otherwise, this is a CLOSED BOOK Examination.
3. Answer BOTH questions #1, and #2. Answer ONLY TWO of questions #3, #4, or #5. Answer ONLY ONE of questions #6 or #7 and ONLY ONE of questions #8 or #9. SIX questions constitute a complete paper.
4. The marks assigned to each question are shown in the left margin.

QUESTIONS #1 AND #2 MUST BE ANSWERED.

- (10) 1. Schematically show the shear force and bending moment diagrams for the following structures. All members have the same EI and are inextensible.

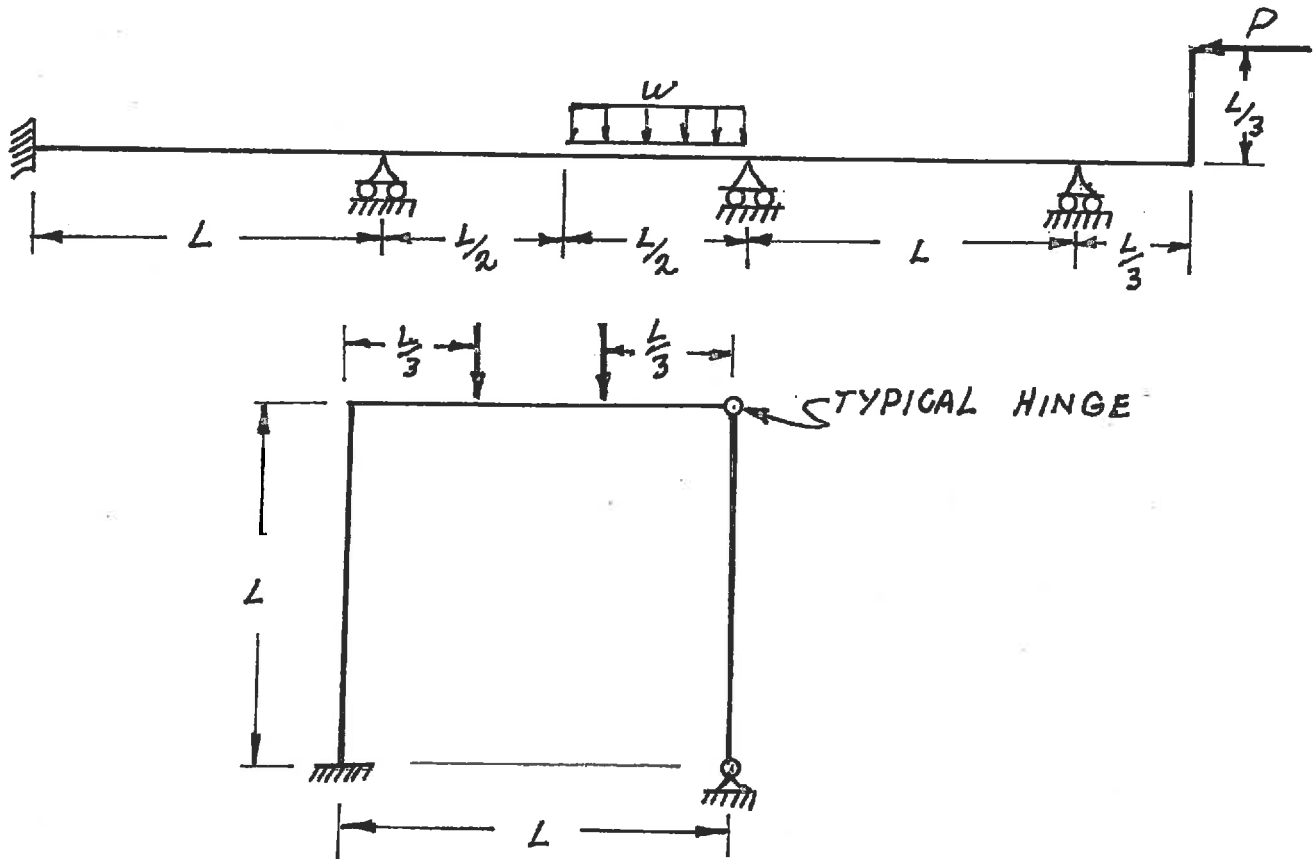

- (10) 2. Sketch the following influence lines for the three-span beam shown below:
- Reaction at support (B)
 - Moment at the middle of span (A-B)
 - Deflection at the middle of span (A-B)
 - Shear immediately left of support (B).

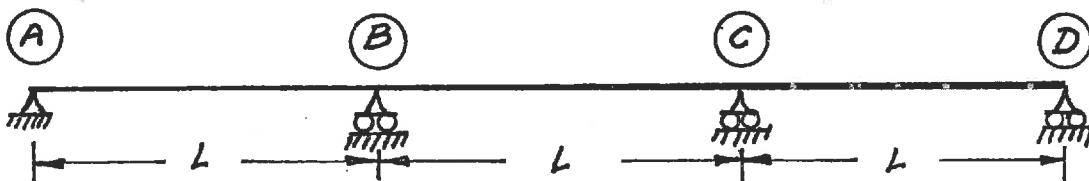

SELECT AND ANSWER TWO QUESTIONS ONLY FROM QUESTIONS #3, #4, OR #5.

- (20) 3. Using a flexibility (force) method, determine the fixed-end moments for the left and right ends of the fixed-ended, non-prismatic beam shown below. Take advantage of symmetry.

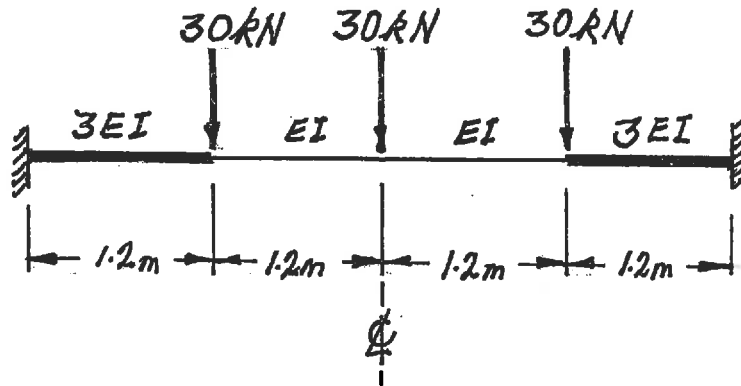

- (20) 4. Use Castigliano's theorem (the "least work" theorem) to analyse the truss shown. Calculate the force in each of the three members. AE is the same for all members.

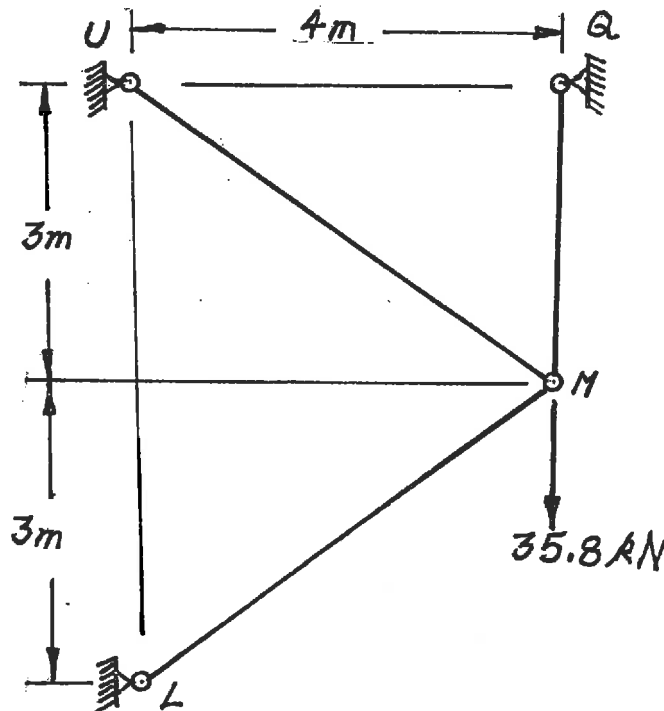

SELECT AND ANSWER TWO QUESTIONS ONLY FROM QUESTIONS #3, #4, OR #5.

- (20) 5. After fabrication, the temperature of the frame shown increased by 32 degrees C causing each member to lengthen.

Change in length = $Q \times L \times (\text{change in temperature in degrees C})$
where:

Q = coefficient of expansion = 1.0×10^{-5} m/m/degree C

L = member length

Use the slope-deflection or moment-distribution method to analyse the frame structure shown. Draw shear and bending moment diagrams. On both diagrams, for each member, indicate the magnitude of maximum and minimum ordinates (Minimum ordinates are frequently negative values). There are no loads on the structure. Members of the structure have the relative EI values shown where $EI = 1.0 \times 10^6$ kN.m². Neglect the effects of axial strain caused by axial forces.

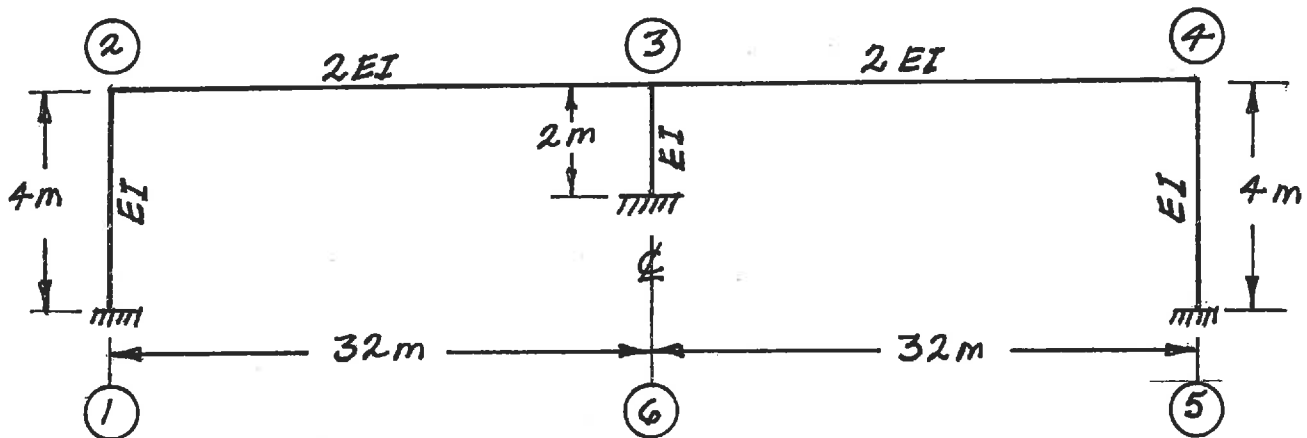

SELECT AND ANSWER ONE QUESTION ONLY FROM QUESTIONS #6, OR #7.

- (20) 6. THE FOLLOWING STATEMENT IS FOR BOTH QUESTIONS #6 AND #7. Using the slope-deflection method or the moment-distribution method, analyse the structure shown. Draw shear force and bending moment diagrams. On each diagram, for each member, indicate the magnitudes of the maximum and minimum ordinates (Minimum ordinates are frequently negative values). All members are inextensible and the relative EI values are shown on the structure. Where possible take advantage of symmetry to simplify your work.

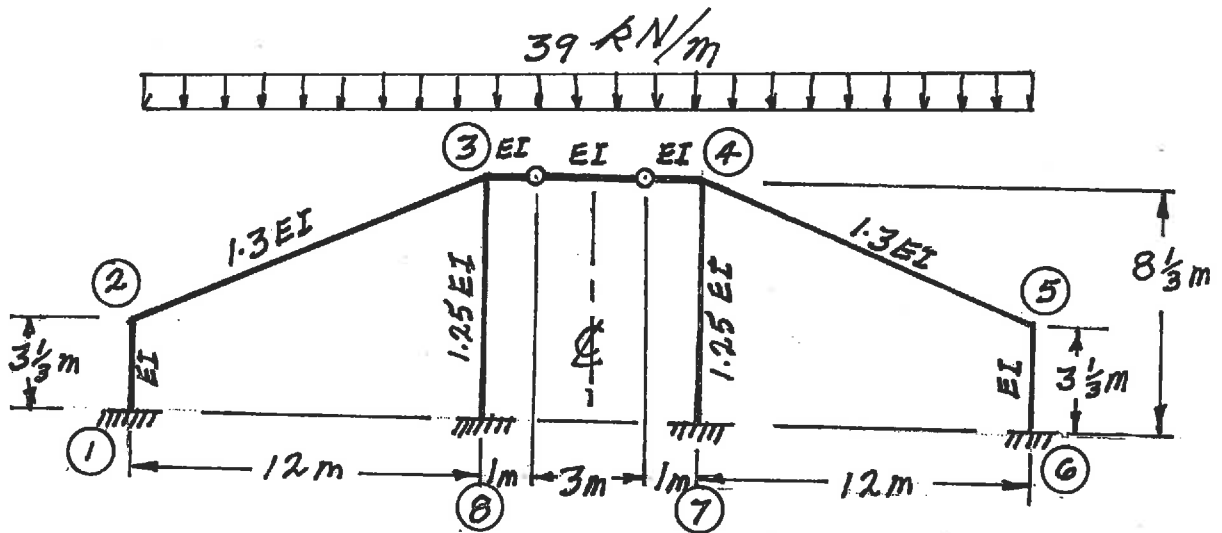

- (20) 7.

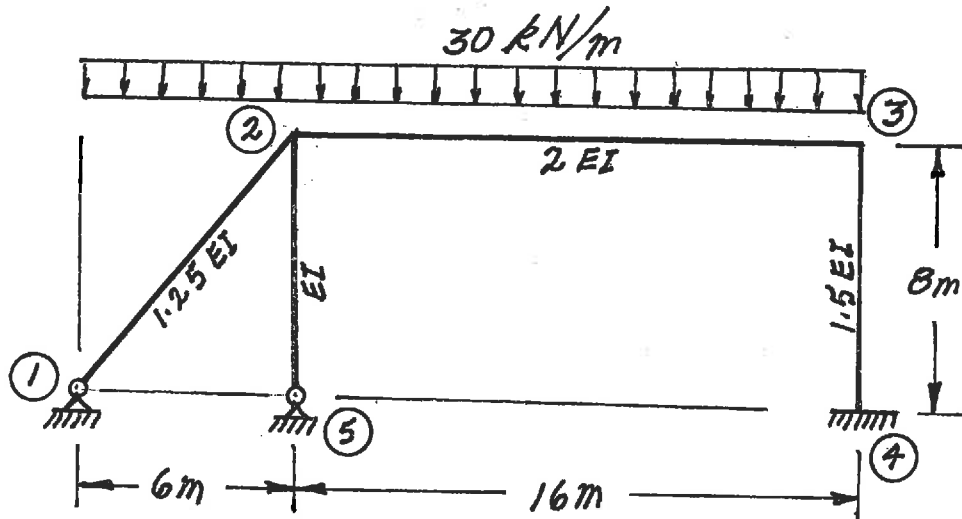

SELECT AND ANSWER ONE QUESTION ONLY FORM QUESTIONS #8 OR #9.

- (20) 8. Using the slope-deflection method or the moment-distribution method, analyse the structure shown below. Take advantage of symmetry or anti-symmetry. Draw shear force and bending moment diagrams. On each diagram, for each member, indicate the magnitude of the maximum and minimum ordinates (Minimum ordinates are frequently negative values). All members are inextensible and have the same EI value.

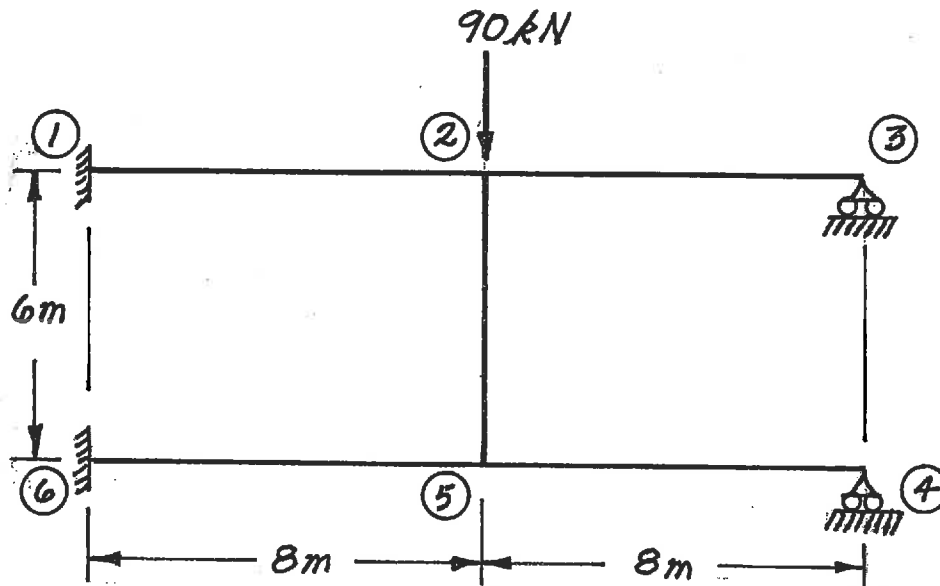

SELECT AND ANSWER ONE QUESTION ONLY FORM QUESTIONS #8 OR #9.

- (20) 9. a) For the frame shown, derive the equilibrium equation for the translation shown at joint ②. Neglect the effects of axial strain. EI has the same value for all members.
- b) Derive the equilibrium equations for moment equilibrium at joints ② and ③.
- c) Present your results in matrix form by giving the terms of the stiffness matrix [K] and the load vector {P} in the following equation:

$$[K] \begin{Bmatrix} \delta \\ \theta_2 \\ \theta_3 \end{Bmatrix} = \{P\}$$

DO NOT SOLVE THE EQUATIONS.

The unknowns of the problem shall be:

δ = translation at joint ② (positive in direction shown)

θ_2 = rotation of joint ②
 (counter clockwise positive)

θ_3 = rotation of joint ③

