

National Exams May 2011

04-BS-15, Engineering Graphics & Design Process

3 hours duration

NOTES

1. If doubt exists as to the interpretation of any question, the candidate is urged to submit with the answer paper, a clear statement of any assumptions made.
2. This is a CLOSED BOOK examination. Candidates may use one of two calculators, the Casio or Sharp approved models.
3. Aids allowed:
 - a. Straight edge
 - b. Engineering squares or rolling ruler
 - c. Pencil and eraser
 - d. Engineering scale
 - e. Protractor
 - f. Compass
4. Ten (10) questions constitute a complete exam paper. Clearly label the answers in the answer book.
5. All questions are of equal value.
6. Failure to follow the above directions will result in grade penalties.
7. All questions have a grading rubric attached. The rubric (with the headings *criterion* and *grade*) is a guideline that will be used to assign marks and penalties.
8. All sketches must be made freehand (without use of any aids) and must be easy to read and neat. Drawings should be made with a straight edge and any other allowed aid.

EXAMINATION QUESTIONS

1. Shown below is an isometric pictorial of an artifact. Sketch or draw an orthographic projection of the artifact. Select and position principal, section, and auxiliary views as necessary. Use common Canadian (CSA/ANSI) conventions and practices. Do not dimension.

Criterion	Grade
Selection of views	3: Minimum necessary views 2/1: More views present than necessary 0: Missing views
Adherence to conventions	3: Flawless 2: Minor omissions 1/0: Incorrect application of conventions
Correctness of projections	4: Flawless 3: Minor errors 2: One or more significant omissions 1/0: Part could not be manufactured

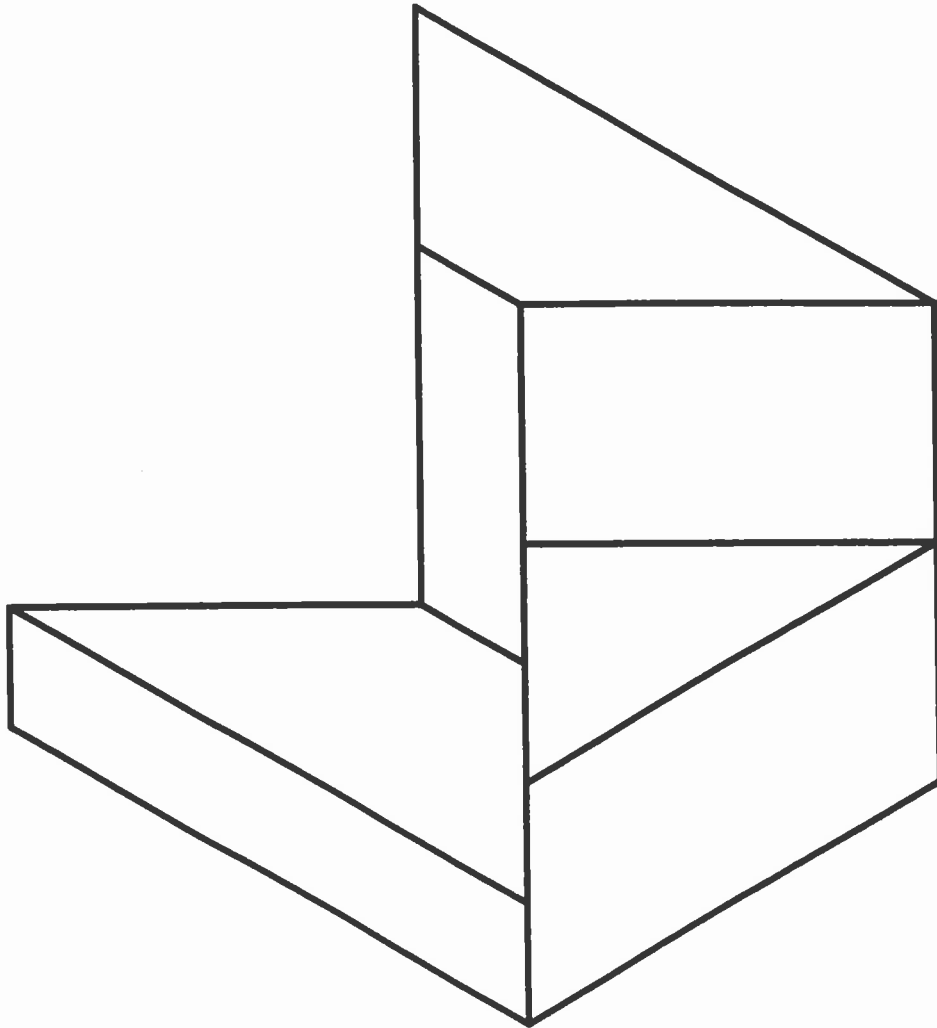

2. Sketch an isometric pictorial of the following orthographic projection. Sketch; do not draw. Do not use a straight edge.

Criterion	Grade
Isometric pictorial	4: Correct angles of horizontal lines 3: Near correct angles of horizontal lines 0: Not an isometric pictorial
Correctness of projection	4: Flawless 3: Minor errors 2: One or more significant omissions 1/0: Part could not be manufactured
Penalties	-10: use of straight edge

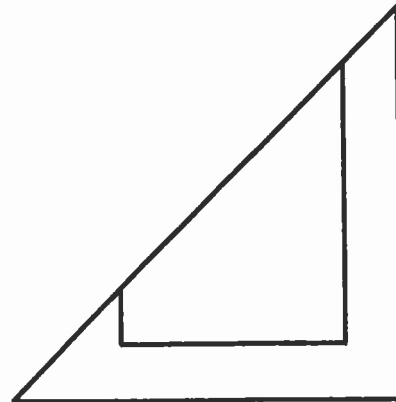
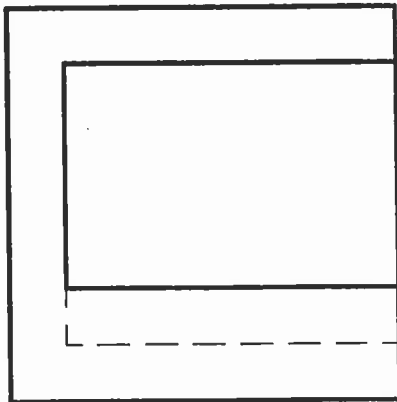
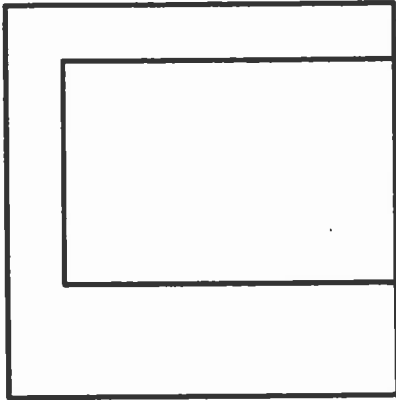

3. Draw the appropriate auxiliary views. Show all work. Clearly label the auxiliary views. Complete the answer in the space provided below.

Criterion	Grade
Selection of views	2: Two correct auxiliary views 1: One correct auxiliary view
Adherence to conventions	3: Flawless 2: Minor omissions 1/0: Incorrect application of conventions
Correctness of projections	4: Flawless 3: Minor flaws 0: True shape not obtained

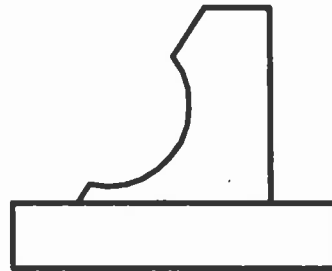
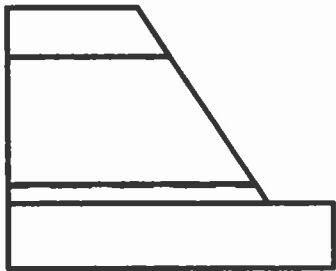

4. Dimension the following orthogonal projection using Canadian conventions (CSA/ANSI) in millimetres. The artifact is drawn in half scale. Complete the answer on the drawing provided.

Criterion	Grade
Drawing	10: dimensioned figure
Dimensioning	-1 per unnecessary dimension -1 per missing dimension
Adherence to conventions	-1 per error

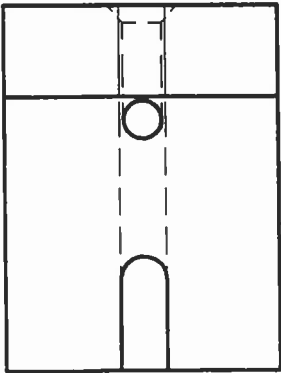
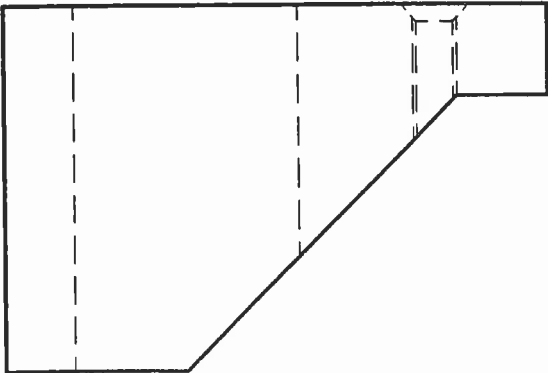
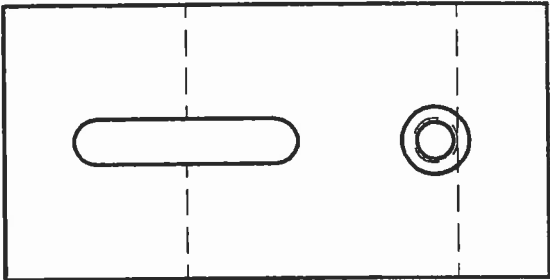

5. Sketch the steps that could be used to construct the following object using primitives (i.e., block, sphere, cylinder, cone, cylinder, prism, torus) using only Boolean operations (union, intersect, subtract).

Criterion	Grade
Overall correctness	10: flawless description of steps to reproduce object 8: minor errors 4: object could not be reproduced

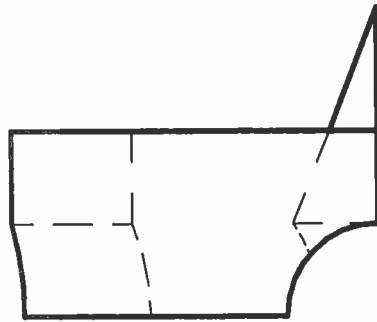
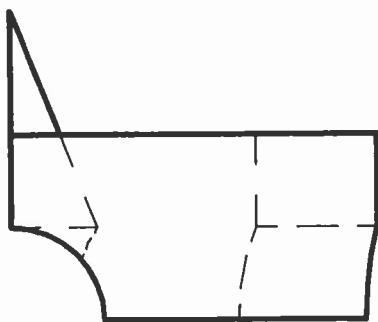
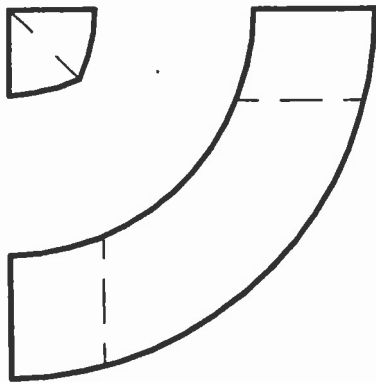

6. Sketch an appropriate section view for the following artifact.

Criterion	Grade
Selection of section view	3: Correct 2/1: Wrong type of section view 0: Inappropriate
Adherence to conventions	3: Flawless 2: Minor omissions 1/0: Incorrect application of conventions
Correctness of projections	4: Flawless 3: Minor errors 2: One or more significant omissions 1/0: Part could not be manufactured

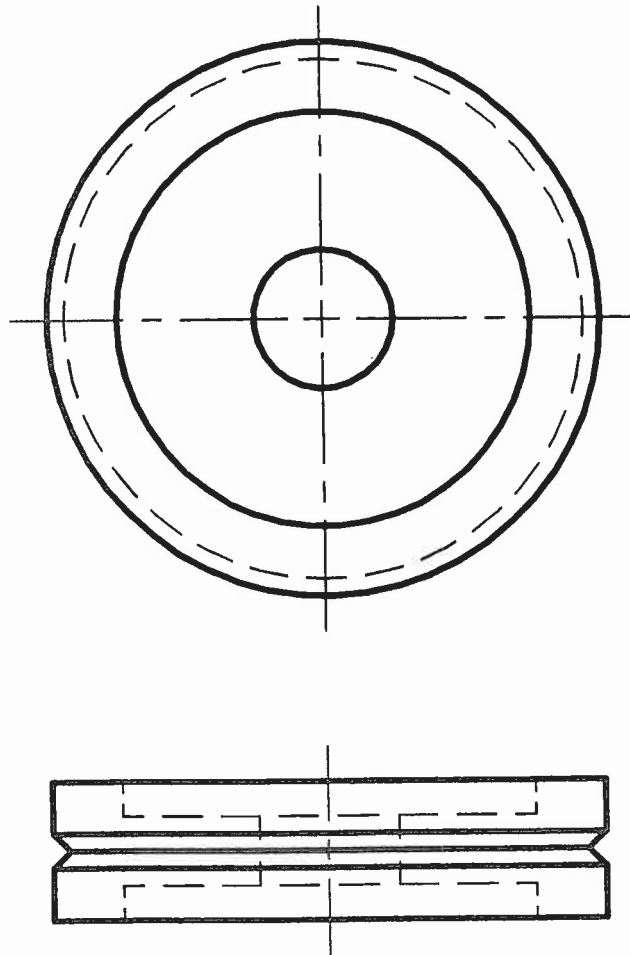

7. For two of the three following acronyms, expand the acronym and explain its significance.

Criterion	Grade
Correct English	-½ per error
Expansion (×2)	2: clear and concise 1: minor flaws
Example (×2)	2: clear and concise

- a. PLM
- b. B-rep
- c. CSG

8. Explain the difference between the terms cavalier oblique, cabinet oblique, and general oblique. Sketch an example of each.

Criterion	Grade
Correct English	1: well written -½ per error
Definition (×3)	2: clear and concise 1: minor flaws
Example (×3)	1: clear and concise

9. For two of the three following terms related to dimensioning, write a paragraph explaining the term and sketch an example.

Criterion	Grade
Correct English	-½ per error
Explanation (×2)	2: clear and concise 1: minor flaws
Example (×2)	2: clear and concise

- a. Coordinate dimension
- b. Out-of-scale dimension
- c. Chain line

10. Sketch an example of each of the following terms.

Criterion	Grade
Identification (×2)	1: Correctly labelled sketch
Sketch (×2)	4: Simple and concise sketch following conventions 3: Minor errors 0: Not a section view

- a. Removed section
- b. Revolved section