

National Exams December 2011

07-Mec-B1 Advanced Machine Design

3 hours duration

NOTES:

1. There is a total of Five (5) questions in this exam.
2. **Question 1 is compulsory.**
3. **Answer three (3) out of the remaining four (4) questions.**
4. State all assumptions clearly. If doubt exists as to the interpretation of any question, the candidate is urged to submit with answer paper, a clear statement of any assumptions made and draw this to the attention of the examiner in the answer booklet(s).
5. Assume any missing data and make sure to properly state it in your answer.
6. Clarity and organization of the answer are important. Write your equations in symbol form first, and put your intermediate and final results in boxes.
7. All answers must be clearly annotated with a summary of approach, method, and use of correct English.
8. Each question is of equal value.
9. Total marks are 100.
10. This is an OPEN BOOK EXAM. Any non-communicating calculator is permitted.
11. Failure to follow the above directions will result in grade penalties.

Question 1 (25 points)

A single block brake commonly used on the railway trains and tram cars is shown in the Figure below. After applying the 2kN actuating force, the clockwise rotating drum comes to a complete stop in 5 seconds. During this time the drum makes 120 revolutions. The coefficient of friction between the drum and lining is 0.4. Perform the following;

- Sketch the brake shoe and arm assembly as a free body diagram.
- Determine the torque that may be transmitted by the block brake.
- Calculate the horizontal and vertical reaction forces at point A.
- Is the brake self-locking for the direction of drum rotation as shown?
- Determine the energy dissipated to bring the drum to a complete stop.
- To make the brake self-energizing for the clockwise rotation, what should be the size of d ?

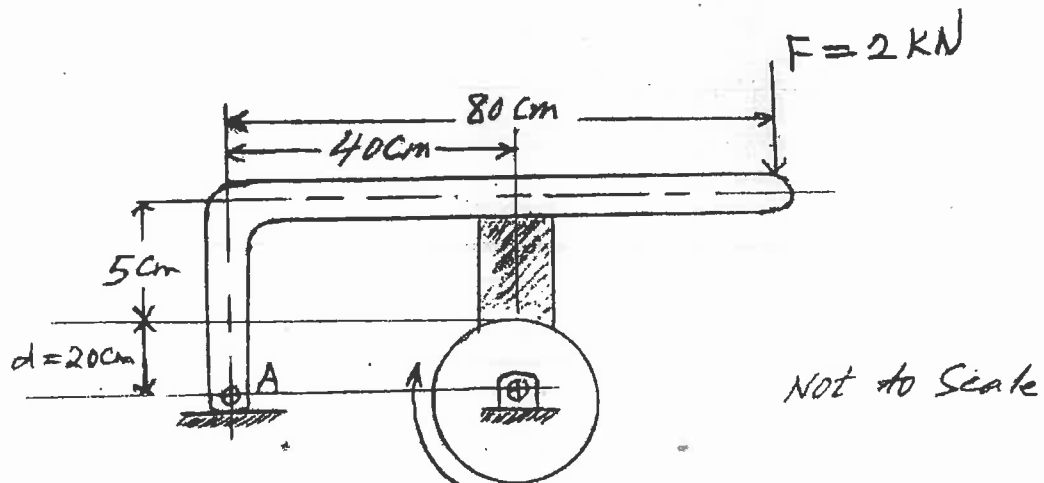

Question 2 (25 points)

A sleeve bearing has a diameter of 3.75-in and it is 6-in long. The shaft speed is 1200 rpm and oil temperature is 180 °F. The friction loss in the bearing is 0.2 hp. The diametric clearance between the journal and bearing is 0.005-in. The eccentricity can be considered as 0.8. Determine the following;

- The total load on the bearing.
- The average pressure in the oil film.
- The stationary and rotating torques.
- The minimum oil film thickness.

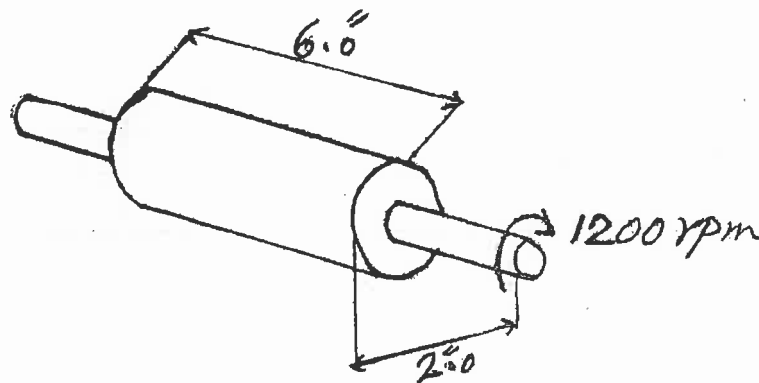

Question 3 (25 points)

A single plate automobile clutch is to transmit a maximum torque of 300 N-m at 2100 rpm. The outside diameter of the clutch is 250 mm and the clutch is engaged at 60 km/h. The engine torque during engagement is 120 N-m and the mass of automobile is 1500 kg. Diameter of the automobile wheel is 0.7 m; gear reduction ratio at differential is 5.0; torque at rear wheels available for accelerating the automobile is 175 N-m. Moment of inertia of combined engine rotating parts, flywheel and input side of the clutch is 1 kg-m². Coefficient of friction for the clutch material is 0.25 and permissible pressure is 0.13 MPa. Assuming uniform wear of the clutch.

Determine the following;

- a) The number of revolutions of the clutch slip during engagement.
- b) Cooling requirement by the clutch for each engagement.

Question 4 (25 points)

A single square thread power screw has 3kW input power with a rotating speed of 1 rev/sec. The screw has an outside diameter of 36 mm with one continuous thread having a pitch 6 mm. The frictional coefficients are 0.14 for the thread and 0.09 for the collar, with an effective collar friction radius of 45 mm. Determine the following;

- a) Show that screw has a pitch diameter of 33 mm.
- b) The size of the load being moved by the screw.
- c) The screw efficiency.

Question 5 (25 points)

A 15,000 lb elevator is supported by a steel wire rope having 2.0-in² cross-section and an effective modulus of elasticity of 12×10^6 psi. Due to an unexpected accident the steel wire rope 50 ft above the elevator suddenly stopped. At the time of accident the elevator was running at a constant speed of 300 ft/min. Determine the following;

- a) Impact factor due to sudden stop.
- b) The maximum elongation of the rope.
- c) Maximum tensile stress developed in the wire rope.

Marking Scheme

- Question 1. 25 points total
a) 4 points
b) 5 points
c) 4 points
d) 4 points
e) 4 points
f) 4 points
- Question 2. 25 points total
a) 17 points
b) 2 points
c) 4 points
d) 2 points
- Question 3. 25 points total
a) 20 points
b) 5 points
- Question 4. 25 points total
a) 5 points
b) 15 points
c) 5 points
- Question 5. 25 points total
a) 15 points
b) 5 points
c) 5 points